

REV	ECO#	DATE	REVISION RECORD	DWG.BY	APPR.BY
1		8-8-02	ORIGINAL SUBMITTAL	LAL	LM
2	030816	10-15-03	NEW FORMAT NEW TITLE BLOCK	JGO	EA
3	434	1-10-12	NEW PRINT FROMAT	RP	MC

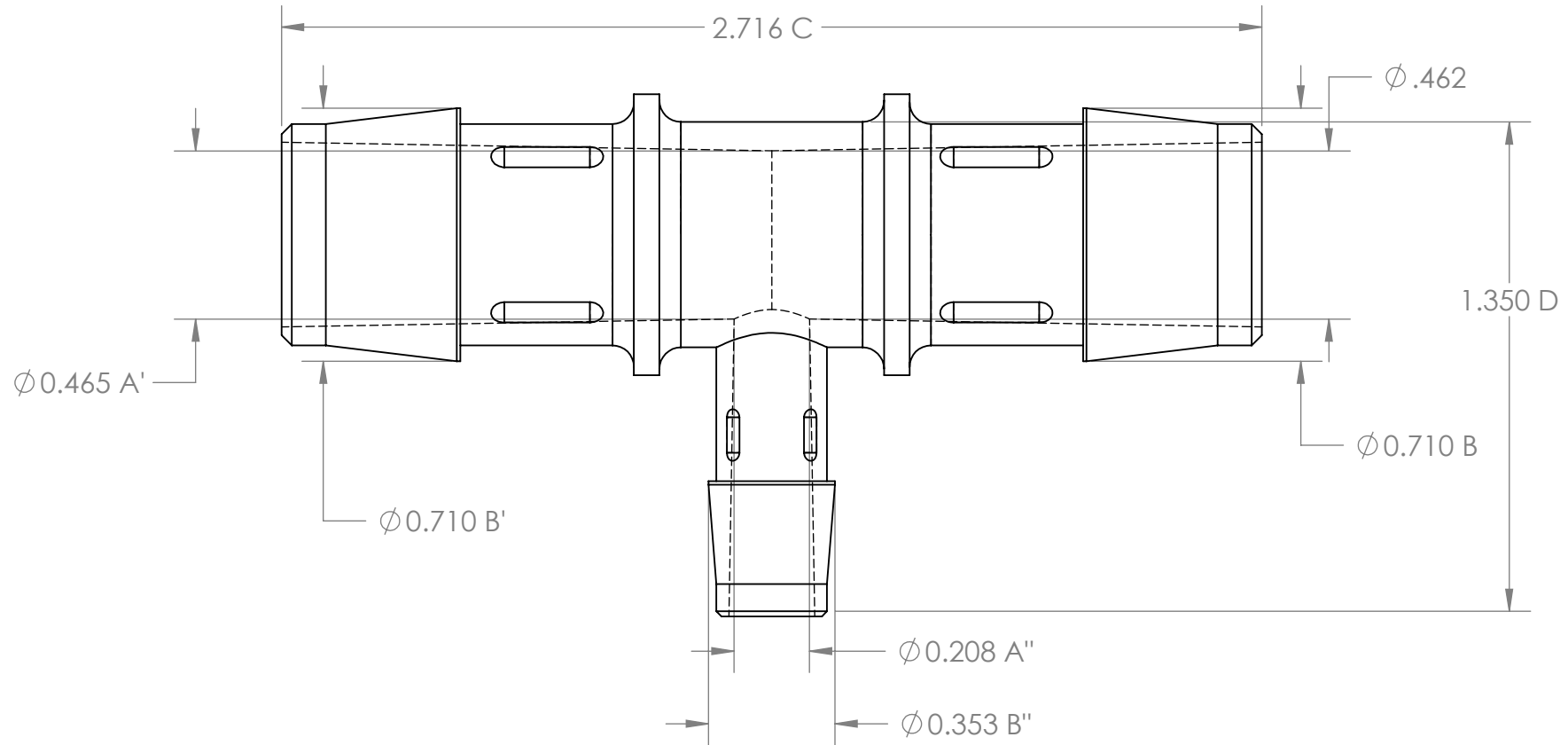

ANTI-ROTATION DEVICE 4 PLACES PER BARB  
 NO MOLD PARTINGLINE PERMITTED ON CONICAL SURFACES  
 ALL DIMENSIONS TYPICAL  
 MATERIAL-316SS  
 VIEW SHOWN LOGO SIDE UP  
 'A' CAVITY DESIGNATED BY A SMALL DOT ON BARB NECK

THIS DRAWING IS ISSUED IN CONFIDENECE FOR ENGINEERING  
 IT MAY NOT BE DISCLOSED OR REPRODUCED WITHOUT  
 WRITTEN PERMISSION FROM ELDON JAMES CORP.

<b>Eldon James</b>				Eldon James Corp. www.eldonjames.com	
DESCRIPTION <b>5/8" X 5/16" SS REDUCTION TEE</b>					
DRAWN BY <b>JGO</b>		APPROVED BY <b>EA</b>		APPROVAL DATE <b>10-15-03</b>	
DRAWING NAME <b>QC DRAWING</b>					
SCALE NTS	SIZE A	SHEET 1 OF 1	TITLE BLOCK REV. A	TOLERANCES UNLESS NOTED OTHERWISE A&B +/- .010 C&D +/- .015	
All printed copies of drawing are for reference only				PART NO. <b>RT10-5SS</b>	REV. <b>3</b>